

Lithium/Manganese Dioxide Battery

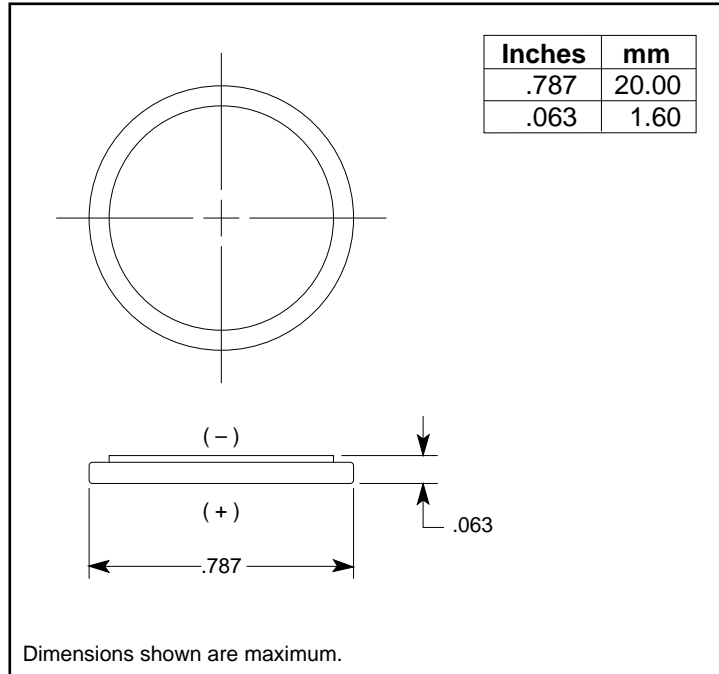

SPECIFICATIONS

Nominal Voltage:	3.0 V
Typical Voltage:	3.1 – 3.3 V
Rated Capacity:	75 mAh on 15 k Ω to 2.0 V at 21°C (70°F)
Average Weight:	0.063 oz. (1.8 g)
Volume:	0.031 in. ³ (0.49 cm ³)
Terminals:	Flat
Operating Temp. Range:	-40°C to 60°C (-40°F to 140°F)
NEDA/ANSI:	5000LC
IEC:	—

